

DL SERIES

DL Series Doors shall be as manufactured or furnished by Republic Doors and Frames, McKenzie, Tennessee 38201. (Standard components are bold.)

Thickness - 1-3/4"

Actual Door Size - Door undersized from nominal by 1/4" in width and 7/8" in height. Standard undercut is 3/4".

Hinge Rail & Reinforcement - Hinge edge is non-beveled and reinforced with a continuous 16 gage steel channel projection welded at a maximum 5" on center. Additional reinforcement plates are provided at the hinge locations to give a total of 3/16" reinforcement. (Backset 1/4")

Lock Rail - Lock edge is non-beveled and reinforced with a continuous 16 gage channel. 16 gage reinforcements for mortise or cylindrical locks are of an integral type in accordance with ANSI A115 Standards. (Beveled lock edge 1/8" in 2" optional.)

Edge Seams - Overlapping visible seam (standard), continuously welded seamless or intermittently welded seamless - options.

Top Channel - Flush, 16 gage channel, projection welded at a maximum 2-1/2" on center. (Optional - Inverted)

Bottom Channel - Inverted 16 gage channel, projection welded at a maximum 2-1/2" on center.

Cores Available - Honeycomb, Polystyrene, Polyurethane, 250^o Temp Rise or Steel Stiffened.

Face Skins - 20 gage, 18 gage or 16 gage, cold rolled or galvanized steel.

Closer Reinforcement (Option) - 14 gage standard / 12 gage optional. (18" x 6")

Size Availability - Minimum 1'0" x 1'0", Maximum 5'0" x 10'0" (over 4' in width must be steel stiffened)

SDI 100 Level/Model - Level 1 Model 1 (Standard Duty, minimum 20 gage, hollow steel composite)
Level 2 Model 1 or 2 (Heavy Duty, minimum 18 gage, hollow steel composite)
Level 3 Model 1 or 2 (Extra Heavy duty minimum 16 gage, hollow steel composite)

Label Range - Consult Label Section.

Universal Standard/Heavy Weight Hinge - Hinge fillers used to change from heavy weight to standard weight hinge prep.

Handing Design - Non-Handed (Handed optional)

Revised 9/14

DL SERIES - SPECIFICATIONS**TECHNICAL DATA
SHEET No. 105a**

- I. DL Series Doors as manufactured by Republic Doors and Frames, McKenzie, TN 38201 have been tested or adhere to the criteria set forth by the following published standards:
- A. ANSI A250.8-1998 (SDI 100) - Recommended Specifications -Standard Steel Doors & Frames; Steel Door Institute.
 - B. ANSI A250.4 - Test Procedure & Acceptance Criteria for Physical Endurance for Steel Doors & Hardware Reinforcings.
 - C. SDI 111 - Recommended Standard Details - Steel Doors & Frames.
 - D. SDI 112 - Zinc Coated Standard Steel Doors and Frames.
 - E. SDI 113 - Test Procedure and Acceptance Criteria for Acoustical Performance for Steel Door and Frame Assemblies.
 - F. ASTM A366/A366M - Standard Specification for Steel, Sheet, Carbon, and High Strength, Low Alloy, Hot Rolled and Cold Rolled, General Requirements.
 - G. ASTM A568/A568M - Standard Specification for Steel, Sheet, Carbon and High Strength, Low-Alloy, Hot Rolled and Cold Rolled, General Requirements For.
 - H. ASTM A569/A569M - Standard Steel Specification for Steel, Carbon (0.15 Maximum Percent), Hot Rolled Sheet and Strip Commercial Quality.
 - I. ASTM A591/A591M - Standard Steel Specification for Steel Sheet, Electrolytic Zinc-Coated, for Light Coating Mass Applications.
 - J. ASTM A653/A653M - Standard Specification for Steel Sheet, Zinc-Coated (Galvanized) or Zinc-Iron Alloy Coated (Galvanized) by Hot Dipped Process.
 - K. NFPA 80 - Standard for Fire Doors and Windows.
 - L. ANSI A151.1 - Performance Test for Steel Doors, Hinge, Lock and Exit Device Reinforcing.
- II. Door Construction
- A. Doors will be constructed of 20, 18 or 16 gage steel.
 - B. Top Channel will be 16 gage, flush with the top of the door and will be projection welded on maximum 2-1/2" centers to each face sheet.
 - C. Bottom Channel will be 16 gage, inverted and will be projection welded on maximum 2-1/2" centers to each face sheet.
 - D. Hinge reinforcing will be a full height 16 gage channel with additional reinforcing at hinge locations to total 3/16" thickness, projection welded to both face sheets with a maximum of 5" on center.
 - E. Lock edge is non beveled with a continuous 16 gage channel welded to both face sheets with a maximum of 5" on center. Cylindrical and mortise lock preps are extruded to 14 gage as specified in ANSI A250.8.
 - F. Cores: (Per ASTM C1363)
 - 1. Standard - 3/4" cell honeycomb with a "U" factor of .59.
 - 2. Optional Cores- 1 lb density expanded Polystyrene per with a "U" factor of .41
2 lb Polyurethane per with a "U" factor of .39
250° Temperature Rise Mineral Fiberboard capable of withstanding a maximum of 250° temperature rise in 30 minutes. With a "U" factor of .56
Steel Stiffened (20 gage standard) with mineral wool or fiberglass batting. With a "U" factor of .61
- III. Door Finish
- Doors will be cleaned and phosphatized with one coat of force-cured grey primer applied in accordance with ANSI A224.1-1990 or ASTM specification B117 for finishes capable of passing 120 hour salt spray test and a 240 hour humidity test in compliance with ASTM D1735.
- SDI Classifications:
- Level 1 Model 1 (Standard Duty, minimum 20 gage, hollow steel composite)
 - Level 2 Model 1 or 2 (Heavy Duty, minimum 18 gage, hollow steel composite)
 - Level 3 Model 1 or 2 (Extra Heavy Duty minimum 16 gage, hollow steel composite)

Revised 8/16

DL SERIES - DOOR CONSTRUCTION DETAILS

TECHNICAL DATA SHEET No. 105b

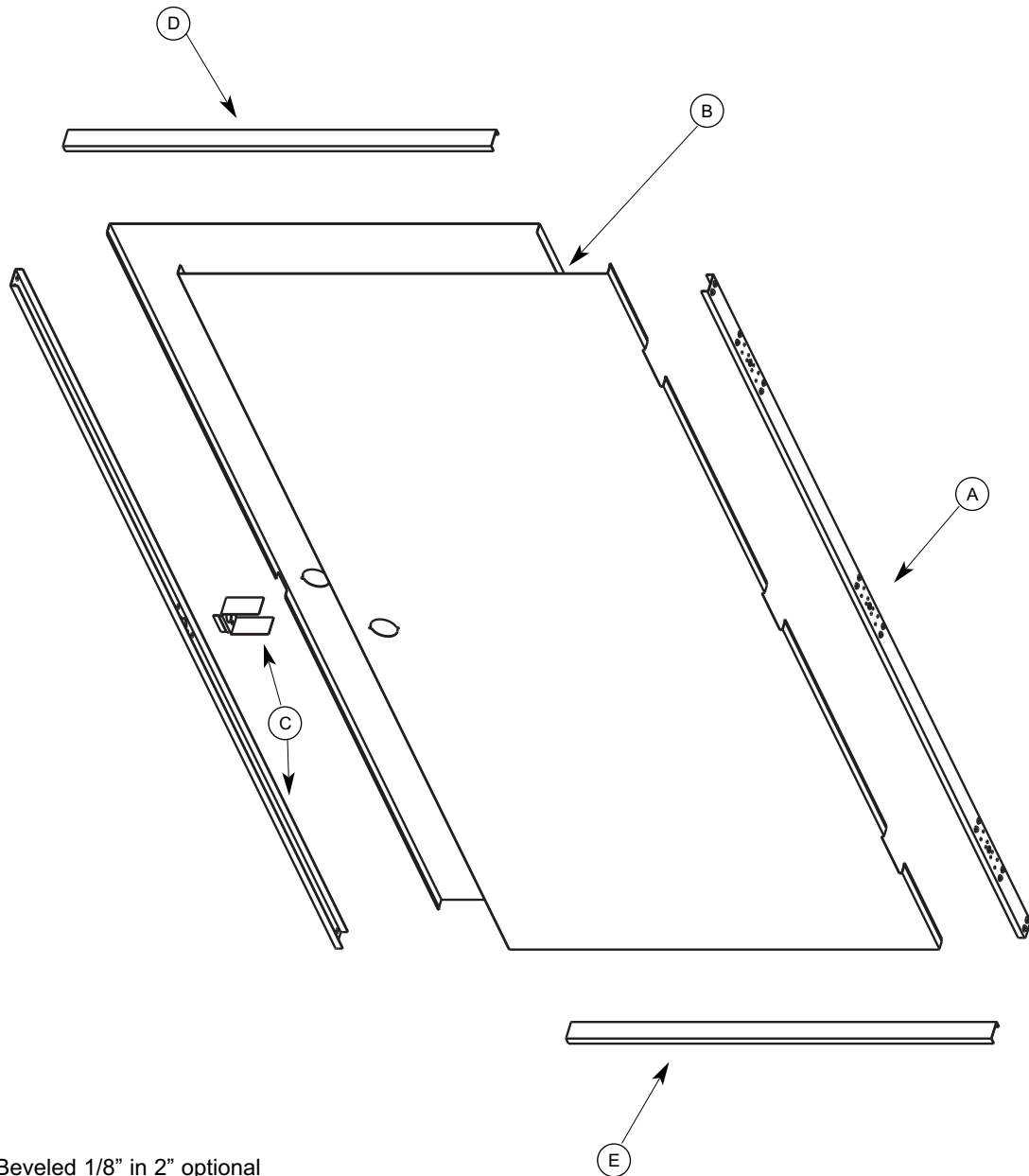

Beveled 1/8" in 2" optional
(lock side only)

NOTE:
See Details on
back of page.

Revised 9/14

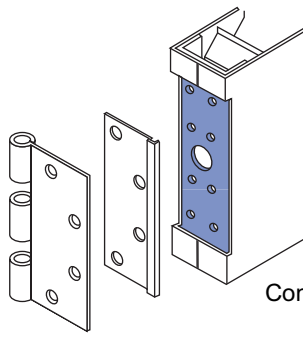
A**Continuous Hinge Channel**

Continuous 16 gage channel with additional reinforcement at hinge locations

Shown: 4-1/2" or 5" full mortise template hinges on 1-3/4" doors

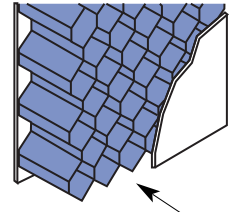
B

3/4" Cell Honeycomb Core (Standard)
U Factor of .59
(Per ASTM C1363)

Other cores available please specify.

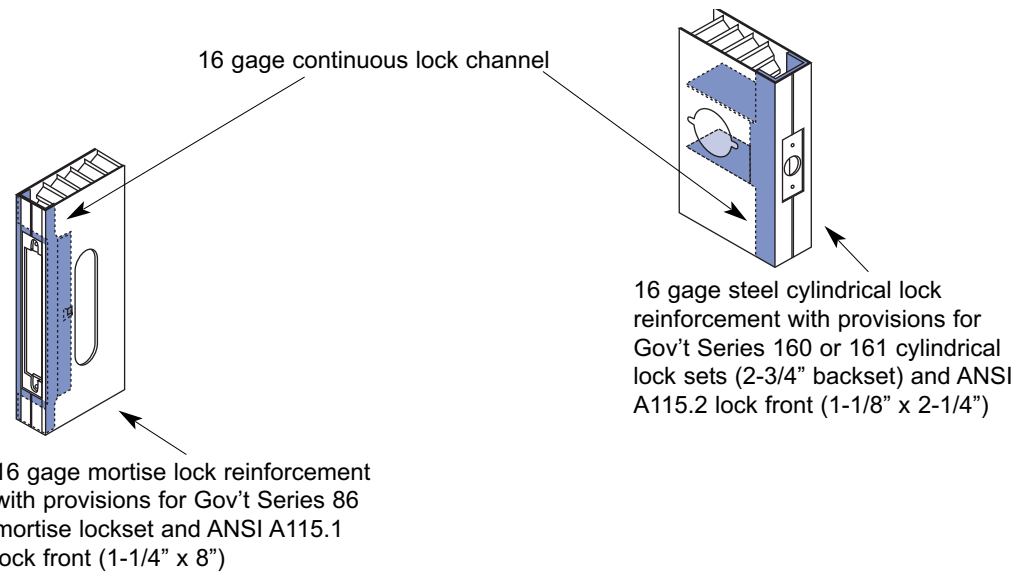
C**16 gage continuous lock channel**

16 gage mortise lock reinforcement with provisions for Gov't Series 86 mortise lockset and ANSI A115.1 lock front (1-1/4" x 8")

16 gage steel cylindrical lock reinforcement with provisions for Gov't Series 160 or 161 cylindrical lock sets (2-3/4" backset) and ANSI A115.2 lock front (1-1/8" x 2-1/4")

D

Continuous 16 gage steel channel (standard flush)

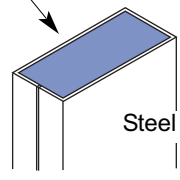
DOOR TOP**Steel Panel**

When closer reinforcement requested 14 gage standard / 12 gage optional

E**DOOR BOTTOM**

Approximate depth 9/16"

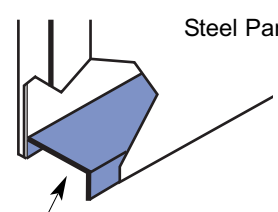
**Steel Panel**

Continuous 16 gage steel channel (standard inverted)

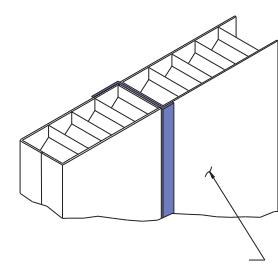

Astragal for double doors (option)